

**C-SERIES MINI EXCAVATORS
CX26C | CX37C**

CASE
CONSTRUCTION



**VERSATILITY
IN MOTION**

www.casece.com

**EXPERTS FOR THE REAL WORLD
SINCE 1842**

CASE BRAND HERITAGE MORE THAN 175 YEARS OF PRIDE AND COMMITMENT

VERSATILITY AND CONVENIENCE



EXPERTS FOR THE REAL WORLD SINCE 1842

- 1842** Jerome Increase Case founded Racine Threshing Machine Works in Racine, Wisconsin, USA.
- 1912** CASE manufactures road building equipment.
- 1969** CASE begins skid steer loader production.
- 1988** CASE recognized by Fortune magazine: listed by Fortune magazine among the "100 Products America Makes Best."
- 1995** CASE expands attachment offering: co-branding and supply agreements with several key attachment suppliers.
- 2011** CASE leads Tier 4 solutions.
- 2011** Long Enters Hall of Fame: CASE engineer, "father of the loader/backhoe", is inducted into the Construction Equipment Hall of Fame.
- 2016** CASE starts the production of C-Series mini excavators up to 5t in San Mauro Plant for the global market.

SAN MAURO PLANT AWARDS



ISO 9001
Product quality
since 2008



ISO 14001
Environment quality
2004



ISO 18001
Safety management
2007



ISO 50001
Energy management
2011



HIGH EFFICIENCY

Clean engine and Auto-idle system

- Proven, reliable, fuel efficient, low emission and low noise Kubota T4 Final / Stage IIIA engine (CX26C).
- Reliable and environmentally friendly T4 Final / Stage IIIA Yanmar engine (CX37C).
- Standard "Auto - idle" on CX37C: The engine automatically decelerates to idling speed after five seconds of inactivity. This means less fuel consumption, less noise and less overall wear.

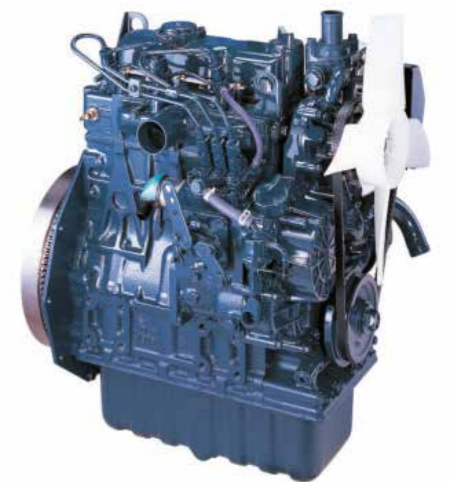

HIGH VERSATILITY

Match different customer needs

- **Working range**
 - Dig further with C-Series Minis: maximum reach is now + 10 % higher compared to the previous series.
 - Load high-sided trucks easily: best-in-class dump clearance combined with superior stability make truck loading an easy task.
 - Save time: C-Series Minis deliver faster cycle times in every combined operation, thanks to their excellent boom slewing speed.
 - Choose the most suitable arm for you: C-Series Minis match different customer needs, high breakout force with short arms or outstanding digging depth and reach with long arms.
- **Attachments:** get the most of your CASE mini with the integrated range of attachments.
- **Lifting:** Both models can be fitted with an additional bolt-on counterweight that further increases stability and lifting capacity. For safe lifting operation machines can be fitted with a certified Object Handling Kit.
- **Travel:** both models have the standard «auto shift-down» feature that optimizes travel speed and traction. Travelling in 2nd speed the machine automatically shifts to 1st gear if it needs more traction, then automatically shifts back to 2nd gear when no extra traction is required and travel speed can be increased.



COMFORT COUNTS

Comfortable and durable cabin with suspension seat

- CASE CX26C and CX37C feature a roomy cab with reduced sound levels and excellent visibility. Ergonomically placed joysticks and adjustable wrist rests make the Operator station a pleasant place to work in.
- Standard equipment: weight adjustable suspension seat, radio USB with 2 speakers, foldable pedals, multiple storage compartments, Air conditioning (optional for CX37C).
- Sliding fold-in front window easy to open and safely stored in an open position to improve ventilation and visibility (Cab type).



SAFETY FIRST

C-Series Minis: no compromise on safety

- **ROPS / TOPS / FOPS:** all C-Series models and versions comply with Roll-Over / Tip-Over and Falling Objects –Protective-Structure requirements.
- **Emergency stop switch:** CX26C and CX37C have as a standard feature a switch that immediately stops the engine in case of an emergency.
- **Pilot system with accumulator:** this standard feature allows the operator to put the attachment down safely even with engine turned off for greater safety.
- **Travel alarm:** an acoustic alarm alerts the people near the machine when it moves forward or backward. This feature is optional on both CX26C and CX37C.
- **Blade safety valves:** prevent the load from slipping or dropping due to hose failure (optional on CX37C).
- **Double-flange rollers:** de-tracking can be dangerous for the operator and the people near the machine. CASE C-Series minis have a double-flange roller design that minimizes the risk of de-tracking.
- **Zero Tail Swing (ZTS):** the ZTS design means no risk of hitting obstacles with the rear of the machine when swinging, and creates less obstruction to road traffic.
- **Object handling kit:** includes safety valves on boom and arm, lifting hook on bucket linkage, and an overload alarm to handle heavy weights safely.



MODERN AND FUNCTIONAL CLUSTER

Easy-to-read digital cluster

- The digital cluster is easy to read, confers a modern look to the operator station and provides useful information:
- Gauges: fuel level, engine coolant temperature
 - Info and warning lamps: hydraulic QC lamp, travel speed, engine coolant temperature, engine oil pressure, battery charging, low fuel level



PEACE OF MIND ESL Anti-theft

- All C-Series minis are equipped with a standard anti-theft. It is an Engine Start Limitation (ESL) requiring a 5-digit code that can be set by the operator
- 3 possible settings:
 1. Always: ESL is engaged every time the machine is shut off
 2. Interval: ESL is engaged after a pre-defined interval of shut off engine
 3. Disabled ESL: ESL is not active



All models are Site Watch telematics pre-wired.

MAIN REASONS TO CHOOSE THE C-SERIES



EXCELLENT WORKING RANGE

- Long and short arms available
- Best-in-class reach, dump clearance and digging depth
- Ample boom swing angles



GREAT RELIABILITY

- X-frame undercarriage
- Cylinder protections
- Low risk of detracking with double-flange rollers



HIGH VERSATILITY

- Offering of integrated attachments
- Mono or bi-directional hydraulic oil flow
- Additional counterweight available
- Steel tracks available (CX37C)



SAFETY FIRST

- ROPS / TOPS / FOPS certified Cab / Canopy
- Emergency stop switch
- Pilot circuit with accumulator
- Object Handling Kit (CX26C / CX37C)
- Blade safety valves (CX37C)



COMFORT COUNTS

- Low noise inside the cab
- 1° and 2° auxiliary hydraulics
- Digital cluster
- Radio with USB
- Suspension seat
- Air Conditioning (CX37C)



HIGH EFFICIENCY

- Auto-idle function (CX37C)



EASY TO TRANSPORT

- Light cab version
- Tie down hooks



GREAT STABILITY

- Higher overall width versus B-Series
- Double-flanged rollers



OPTIMIZED TRACTION AND SPEED

- Auto shift-down
- Rubber or steel tracks (CX37C)



EASY SERVICEABILITY

- Easy access to battery, hydraulic valves and all regular service components
- Two-piece blade hydraulic hoses
- Extended life of components

C-SERIES MINI EXCAVATORS

**GET THE JOB DONE NOW
AND FOR MANY YEARS TO COME**



GREAT RELIABILITY: A GIVEN ON CASE EXCAVATORS

World class components and a well-organized plant

- **World class components:** C-Series minis are designed for reliability, components are sourced from the best suppliers on the market and assembled in CASE's Excavator Hub, a World Class Manufacturing production plant. The result: simply highly reliable machines.
- **Boom and arm reinforced mounting pin:** the pivot pin that holds boom and arm together is a critical point on any excavator. On CASE C-Series the pin is secured from both sides minimizing the risk of play between boom and arm.
- **Protected cylinders:** boom and blade cylinders as well as safety valves are well protected with a steel cover.



EASY AND SAFE SERVICEABILITY

Grouped service points under the hood

C-Series are designed for serviceability:

- Rationalized service points layout
- Convenient check points
- Easy-to-remove side panels for full maintenance and repair access
- Two-piece blade hydraulic hoses

STANDARD EQUIPMENT

Short arm (1120 mm / 1350 mm on CX26C / CX37C respectively)
 Rubber tracks 250 mm / 300 mm (CX26C / CX37C respectively)
 ROPS / TOPS / FOPS compliant Cab / Canopy
 Emergency stop switch
 Pilot system with accumulator
 2 speed travel with auto shift-down system
 1st auxiliary 2-way circuit controlled with pedal
 Foldable boom swing pedal
 Suspension seat with seatbelt
 Radio / USB (Cab version)
 Standard anti-theft with interval setting function
 Waterproof digital instrument cluster
 Centralized greasing inlet

OPTIONAL EQUIPMENT

Long arm (1300 mm / 1600 mm on CX26C / CX37C respectively)
 2nd auxiliary circuit controlled with joystick
 Hydraulic quick coupler provision
 Beacon
 Travel alarm
 Additional counterweight
 Air conditioner (CX37C)
 Steel track (CX37C)
 Blade safety valves (CX37C)
 Object Handling Kit

Standard and Optional equipment may vary. Consult your CASE dealer for details.

C-SERIES MINI EXCAVATORS

SPECIFICATIONS

SPECIFICATIONS

ENGINE

	CX26C	CX37C
Model	Kubota D1305	Yanmar 3TNV88F
Displacement (cm ³)	1261	1642
Rated gross horse power (hp/kW) (ISO 14396)	24.8 / 18.5	24.4 / 18.2
@ rpm	2400	2200
Max torque (Nm/rpm)	81 / 1600	89 / 1200
Emissions level	Tier 4F Not Reg. in EU	Tier 4F Not Reg. in EU

HYDRAULIC SYSTEM

	CX26C	CX37C
Variable displacement axial piston pumps	2 x 27.6	2 x 37.4
- Pump delivery (l/min)	220	230
- Pressure (bar)		
Gear pump delivery	19.6	23.1
- Pump delivery (l/min)	175	205
- Pressure (bar)		
1st Auxiliary 2-way Circuit	47.2	60.5
- Pump delivery (l/min)	175	205
- Pressure (bar)		
2nd Auxiliary 2-way Circuit	47.2	60.5
- Pump delivery (l/min)	175	205
- Pressure (bar)		

GENERAL DIMENSIONS

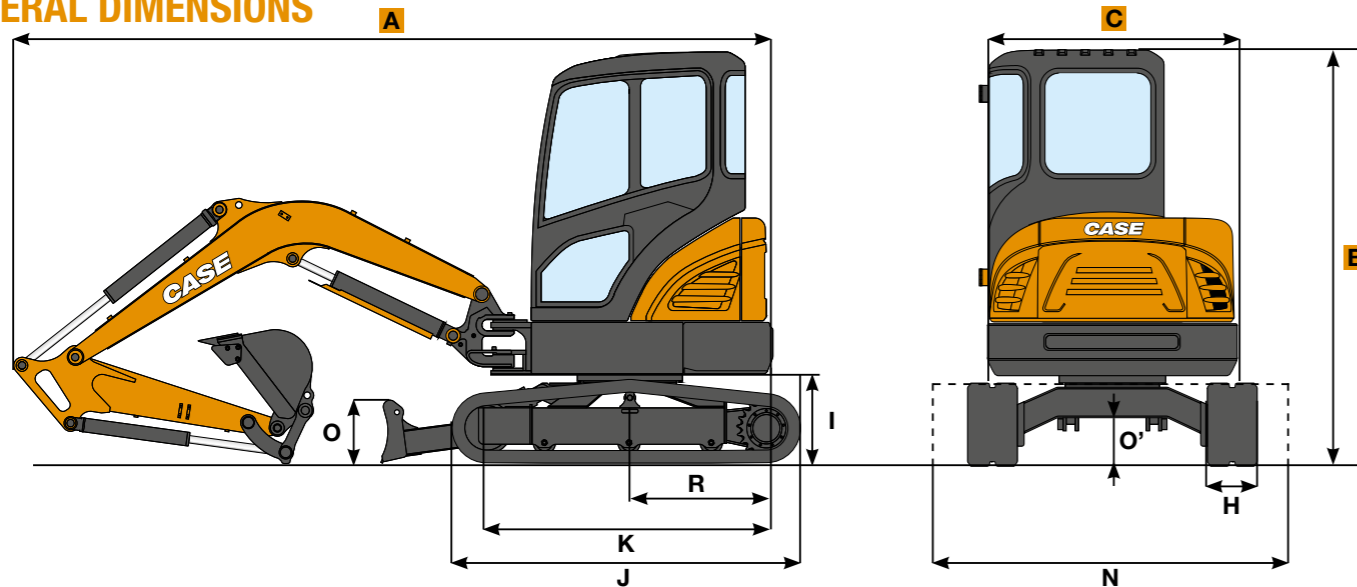

		CX26C	CX37C	
R	Rear end swing radius	mm	775	870
R'	Min front slew radius	mm	1980 - 1970	2350 - 2330
H	Track width	mm	250	300
I	Ground clearance of rear end	mm	510	540
J	Overall Length of Crawler	mm	1910	2130
K	Center distance of tumbler	mm	1490	1700
L	Blade max lifting	mm	330	375
M	Blade max lowering	mm	380	390
N	Blade width	mm	1500	1740
O	Blade height	mm	300	370
O'	Ground clearance of undercarriage	mm	290	290

SLEWING & TRAVEL SPEED

	CX26C	CX37C
Slewing speed (rpm)	9.1	9.5
Boom slewing angle (left/right)	75° / 50°	75° / 50°
Travel Speed - Low (1 st) (km/h)	2.4	2.3
Travel Speed - High (2 nd) (km/h)	4.5	4.4

OPERATING WEIGHT

(includes operator, full fuel tank and one bucket)

	CX26C	CX37C
Cab (kg)	2650	3760
Canopy (kg)	2500	3620

TRANSPORT FEATURE

(weight is with full fuel tank, without operator, without bucket)

	CX26C	CX37C
Weight (Cab) (t)	2560	3660
Weight (Canopy) (t)	2410	3520
A Max length (mm)	4030 4100*	4790 4815*
B Max height (mm)	2500	2500
C Max width (mm)	1500	1740

* Long arm

DIGGING PERFORMANCES

		CX26C		CX37C	
Dipperstick	mm	1120	1350	1300	1600
Dipperstick Breakout force (ISO)	kN	14.6	12.8	19.5	16.9
Bucket Breakout force (ISO)	kN	21.1	21.1	30.7	30.9
D Max reach	mm	4480	4680	5315	5605
D' Max reach at ground level	mm	4340	4540	5200	5495
E Max digging depth	mm	2420	2645	3135	3440
F Max dump height	mm	2930	3030	3425	3615
G Max digging height	mm	4150	4235	4810	5010

LIFTING CAPACITIES

Lift point height (m)	Arm	LIFT-POINT RADIUS		
		1.5 m	2.0 m	3.0 m

CX26C Canopy

Lift point height (m)	kg	LIFT-POINT RADIUS					
		1.5 m	2.0 m	3.0 m	4.0 m		
1.0 m	kg		760	620	400	340	
			*1690	670	*900	360	
0.0 m	kg	*840	*840	710	570	380	310
		*840	*840	*1700	620	*1100	340
-1.0 m	kg	1240	950	710	570	370	310
		*1920	1040	*1910	620	*1030	330

CX26C Cab

Lift point height (m)	kg	LIFT-POINT RADIUS					
		1.5 m	2.0 m	3.0 m	4.0 m		
1.0 m	kg		880	720	460	380	
			*1470	770	*850	410	
0.0 m	kg		810	650	430	360	
			*1580	700	*1070	390	
-1.0 m	kg	1400	1070	800	650	430	350
		*1660	1170	*2000	700	*1070	380

All models are equipped with long arm, no bucket, std counterweight., rubber tracks
ISO 10567: Lifting capacity does not exceed 75% of tipping load or 87% of full hydraulic capacity.

* Indicates load limited by hydraulic capacity

ATTACHMENTS

CASE offers an integrated range of attachments

- Standard buckets from 0.025 to 0.135 m³ SAE Heaped capacity (width from 250 to 800 mm)
- Ditch cleaning buckets
- Mechanical and hydraulic quick couplers (Klac and Lehnhoff-compatible)
- Hydraulic hammers
- Earth augers

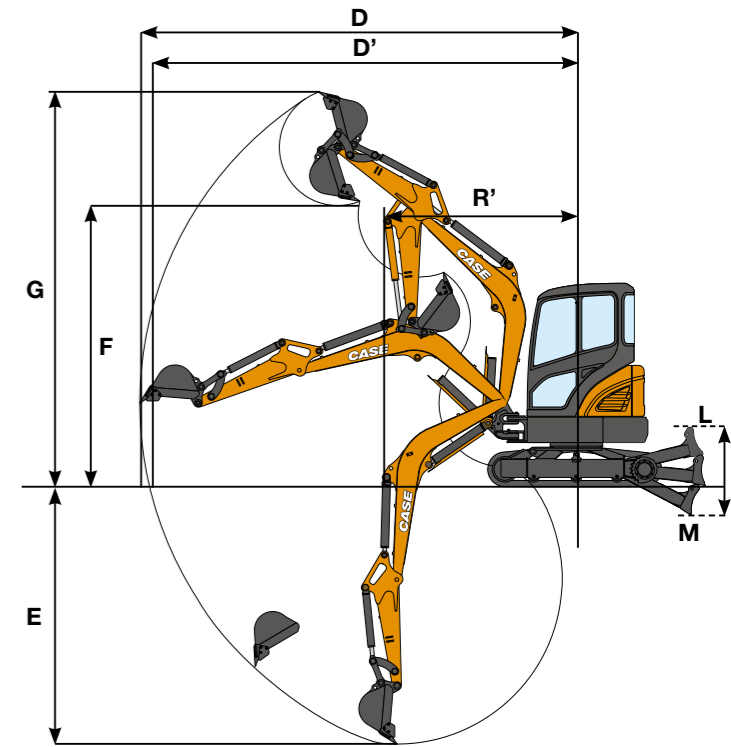

Lift point height (m)	Arm	LIFT-POINT RADIUS		
		2.0 m	3.0 m	4.0 m

CX37C Canopy

Lift point height (m)	kg	LIFT-POINT RADIUS					
		2.0 m	3.0 m	4.0 m	5.0 m		
1.0 m	kg		810	690	520	450	
			*970	750	*690	490	
0.0 m	kg	*1320	1190	760	640	500	430
		*1320	1320	*1160	700	*700	470
-1.0 m	kg	1470	1200	750	630	490	420
		*2060	1330	*1140	690	*750	460

CX37C Cab

Lift point height (m)	kg	LIFT-POINT RADIUS					
		2.0 m	3.0 m	4.0 m	5.0 m		
1.0 m	kg		860	730	550	480	
			*970	800	*690	520	
0.0 m	kg	*1320	1270	810	690	530	460
		*1320	*1320	*1160	750	*770	500
-1.0 m	kg	1570	1280	800	680	530	450
		*2060	1410	*1140	740	*750	490



www.casece.com
EXPERTS FOR THE REAL WORLD
SINCE 1842

CASE
CONSTRUCTION



Form No. 20148GB - Printed in Italy - MediaCross Firenze - 01/17

**CNH INDUSTRIAL
DEUTSCHLAND GMBH**
Case Baumaschinen
Benzstr. 1-3 - D-74076 Heilbronn
DEUTSCHLAND

CNH INDUSTRIAL FRANCE, S.A.
16-18 Rue des Rochettes
91150 Morigny-Champigny
FRANCE

CNH INDUSTRIAL - UK
First Floor, Barclay Court 2,
Heavens Walk,
Doncaster - DN4 5HZ
UNITED KINGDOM

CNH INDUSTRIAL - SOUTH AFRICA
Waterfall Business Park
Bekker Street, Howick Close
1685 Midrand - Johannesburg
REPUBLIC OF SOUTH AFRICA

**CNH INDUSTRIAL
MAQUINARIA SPAIN, S.A.**
Avda. José Gárate, 11
28823 Coslada (Madrid)
ESPAÑA

CNH INDUSTRIAL ITALIA SPA
Strada di Settimo, 323
10099 San Mauro Torinese (TO)
ITALIA

**CASE CUSTOMER CENTRE
PARIS**
RN 330 - Penchard
77122 - Monthyon
FRANCE

CNH INDUSTRIAL - MIDDLE EAST
DAFZA - Dubai Airport Free Zone
West Wing 4 B, Office 642
P.O. Box 54588, Dubai,
UNITED ARAB EMIRATES

NOTE: Standard and optional fittings can vary according to the demands and specific regulations of each country. The illustrations may include optional rather than standard fittings - consult your Case dealer. Furthermore, CNH Industrial reserves the right to modify machine specifications without incurring any obligation relating to such changes.

Conforms to directive 2006/42/EC

CASE
00800-2273-7373

The call is free from a land line.
Check in advance with your Mobile Operator if you will be charged. Toll free number not available from all calling areas.

